

HFJ-700A PLACARD PARTS LIST

ITEM NO.	DESCRIPTION	NO. REQ'D
1	Warning Label (Use Stands to Support Vehicle)	1
2	Jack Position Plate	1
3	Lift Pad Instructions	1
4	Identification Placard, HFJ-700A	1
5	Warning Label (Do Not Adjust)	1

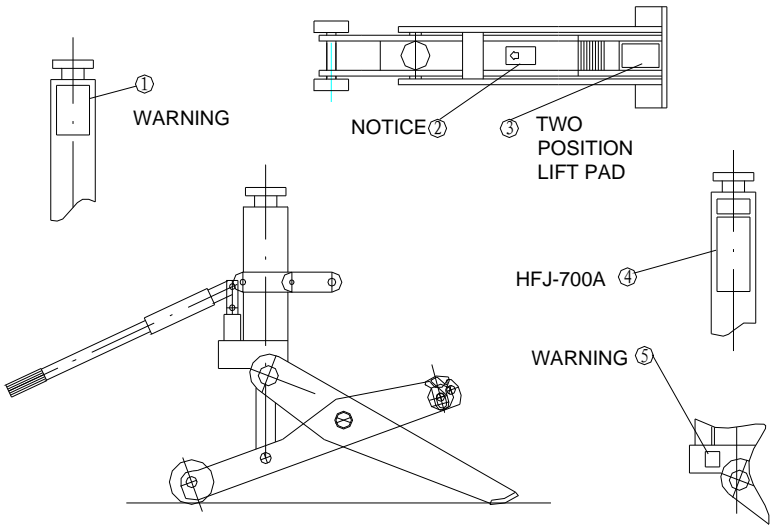

NO	DESCRIPTION	QTY	NO	DESCRIPTION	QTY
01	Screw	2	34	Back-Up Ring	1
02	Lock Washer	4	36	Plunger	1
03	Trunnion	2	37	Retaining Ring	8
04	Frame 1	1	38	Pin	3
05	Screw	2	39	Pin	1
06	Washer	2	40	Link Rod	1
07	Axle	1	41	O-Ring	2
08	Snap Ring	2	42	Back-Up Ring	1
09	Washer	2	43	O-Ring	2
10	Wheel	2	44	Oil Tank	1
11	Frame 2	1	45	O-Ring	2
12	Screw	2	46	Port Ring	1
13	Lock Washer	2	47	Cylinder	1
14	Nut	2	49	Piston	1
15	Spacer	2	50	Valve Seat	1
16	Pin	1	51	O-Ring	1
17	Saddle	1	52	Release Rod	1
18	Pin	1	53	Release Knob	1
20	Screw	2	54	Pin	1
21	Seal Ring	2	55	Chain Hook	1
22	Screw	1	56	Chain	1
23	Spring	1	57	Handle Base	1
24	Ball Seat	1	58	Screw	2
25	Ball	1	59	Handle 1	1
26	Valve Block	1	60	Handle 2	1
27	Magnet Steel	1	61	Grip	1
28	Ball	3	62	Seal Ring	1
29	Spring	1	67	Screw	1
30	Screw	1	70	Piston Rod	1
31	Seal Ring	1	71	Wiper	1
32	Pump	1	72	Y-Ring	1
33	O-Ring	1			

